



Order hook & cable separately

# INDUSTRIAL HAND WINCH

Model No. SF-2200

- 1000kg lifting & 2000kg pulling capacity
- Ratchet handle permits reciprocating handle movement in both directions for lifting and lowering loads
- Positive load-actuated brake can hold the load in any position
- Gears and brake are fully covered to prevent dust, dirt and rain contamination
- Very low operator effort is required for easy operation
- Ratchet handle accommodates installation in cramped locations

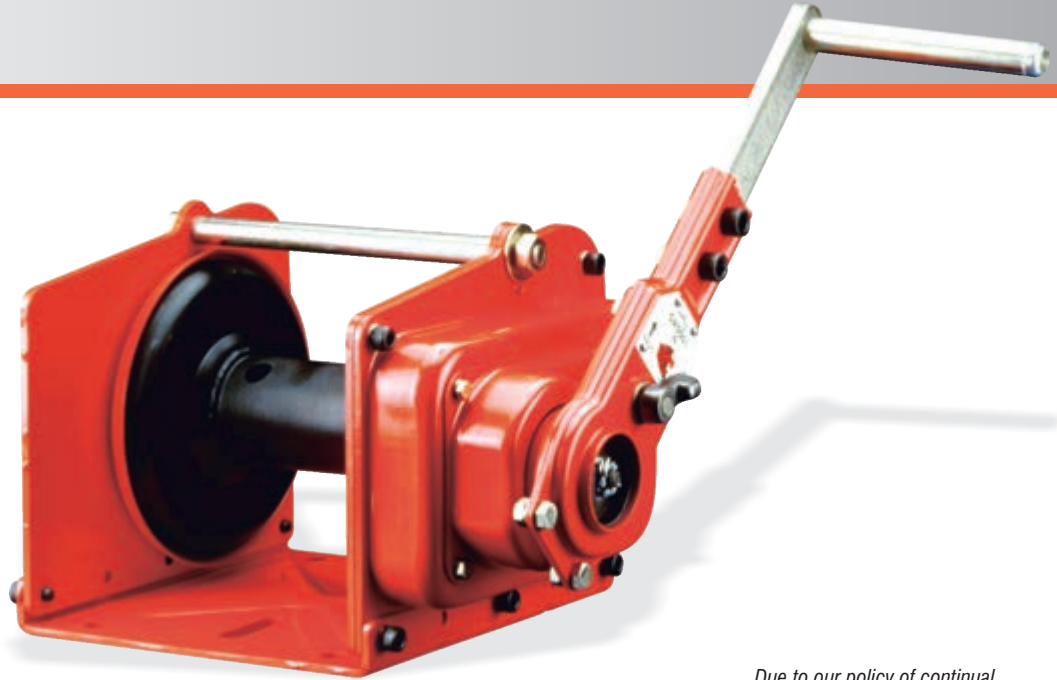

## Technical Specifications

Product Code	Pulling Capacity (kg)	Lifting Capacity (kg)	Hand Force Required (kg)	Gear Ratio	Hub Ø (mm)	Handle Length (mm)	Unit Weight With Handle (kg)	Cable Ø (mm)	Cable Capacity (m)
HWI1000	2000	1000	10	22.2:1	80	300	17.5	8.0	35

Due to our policy of continual product development, dimensions, weights and specifications may change without prior notice. Please check with your sales team when ordering.

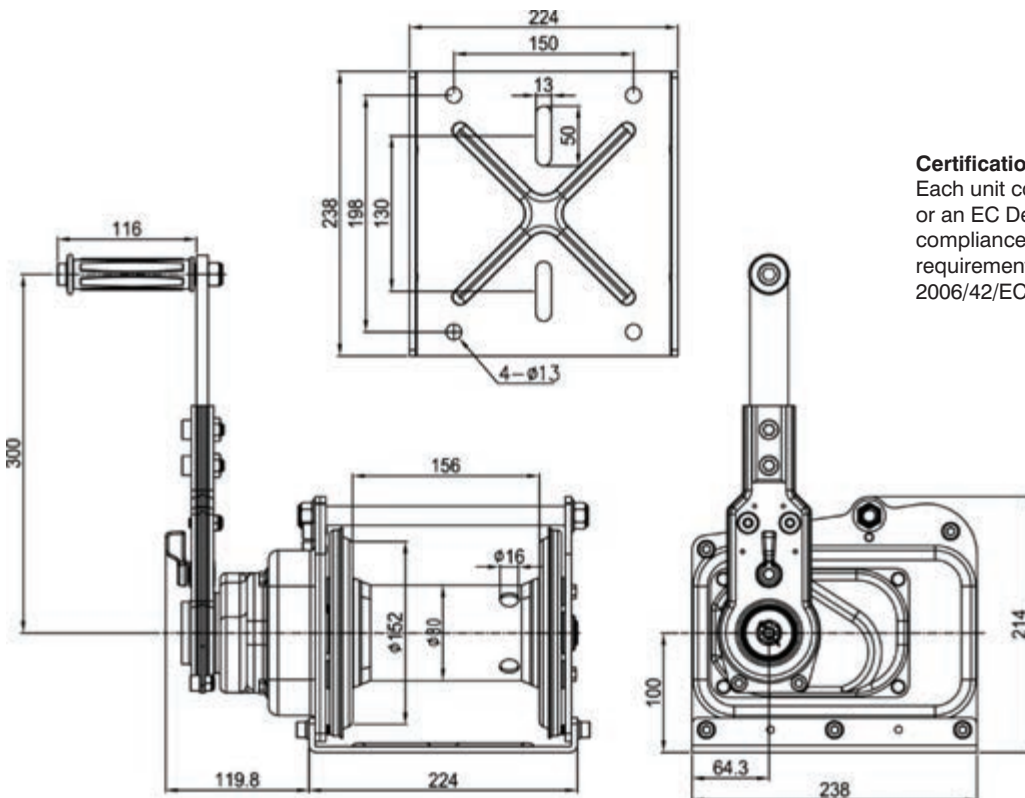

### Certification:

Each unit comes fully certified with a test certificate or an EC Declaration of Conformity stating compliance with the essential health and safety requirements of the Machinery Directive 2006/42/EC.

**SGS**

